

CJRC

CJRC ROTARY JOINT



FEATURES

Apply for Hydraulic, Pneumatic & High Volume Coolant. It adopts the original developed low friction seal and low torque enables smooth rotation. Each part of this rotary joint is highly durable and each seal provided by DESETEC has low torque, highly durable and high capacity design that allows for a longer life of the component. You can select the number of ports from 2, 4, 6, 8 along with the center through port.

OPTIONS

| CLASSIFICATION | THE NUMBER OF THE PORTS | FEATURES | USABLE FLUID |
|------------------------|-------------------------|------------------------------------|--|
| No center Through Port | 2/4/6/8 Port | Low Rotary Torque (Compact Design) | General Hydraulic Oil: 7 mpa Air: 1 Mpa or Less |

ORDERING INDICATION

CJRC-020SA

| CJRC | Series | CJRC |
|------|------------------------------|---|
| 02 | The Number of the Ports | 02 : 2 ports 04 : 4 ports 06 : 6 ports 08 : 8 ports |
| 0 | Center Through Port | 0 : No Center Through Port |
| S | Mounting Direction | B : Piping Option (BSPP Thread (G-Thread)) S : Piping Option (BSPT (Rc-Thread)) |
| A | Secondary Side Piping Method | A : Both Gasket and Piping Options (With BSPT Plug (R-Thread Plug)) D : Both Gasket and Piping Options (With BSPP (G-Thread Plug)) |

1. Contact us, if you need a piping option different than what is shown in model code of catalogue.

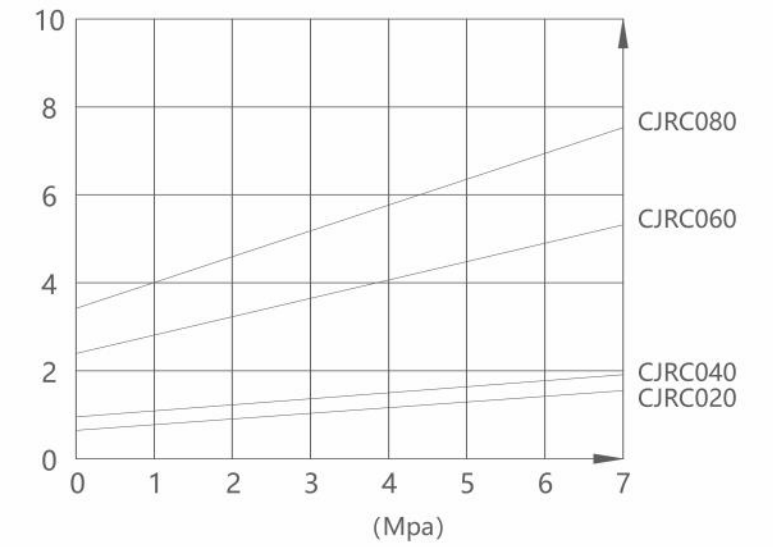

PERFORMANCE CURVE (ROTARY TORQUE: REFERENCE VALUE)

| MODEL | ROTARY TORQUE (N-m) | | | | |
|-------|----------------------|---------|---------|---------|---------|
| | FLUID PRESSURE (Mpa) | CJRC020 | CJRC040 | CJRC060 | CJRC080 |
| 7 | | 1.5 | 1.8 | 5.5 | 7.5 |
| 6 | | 1.4 | 1.7 | 5.1 | 6.9 |
| 5 | | 1.4 | 1.6 | 4.7 | 6.4 |
| 4 | | 1.3 | 1.5 | 4.3 | 5.8 |
| 3 | | 1.2 | 1.5 | 4.0 | 5.3 |
| 2 | | 1.1 | 1.4 | 3.6 | 4.7 |
| 1 | | 1.1 | 1.3 | 3.2 | 4.2 |
| 0 | | 1.0 | 1.2 | 2.8 | 3.6 |

NOTE

1. This graph shows the relationship between the rotary torque and the fluid pressure.
2. The starting torque might be more than double of rotating torque shown in graphic and may change according to the conditions of the stationary down time. It varies according to the condition such as stationary down time.
3. The rotary torque is a reference level.

SPECIFICATION

| MODEL | OPERATING PRESSURE (Mpa) | | Ports | | (7MPa時)※1 | | OPERATING TEMPERATURE(°C) | USABLE FLUID |
|----------|--------------------------|-------|--------|-------------------------------------|---------------------|---|---------------------------|--------------|
| | OIL | AIR | NUMBER | MIN. PASSAGE AREA(MM ²) | CENTER THROUGH PORT | ALLOWABLE ROTARY SPEED (AT 7MPa)※1(MIN-1) | | |
| CJRC-020 | 0~7.0 | 0~1.0 | 2 | 19.6 | Nothing | 280 | 4.5 | -10~70 |
| CJRC-040 | 0~7.0 | 0~1.0 | 4 | 19.6 | Nothing | 280 | 5.5 | -10~70 |
| CJRC-060 | 0~7.0 | 0~1.0 | 6 | 19.6 | Nothing | 200 | 8.0 | -10~70 |
| CJRC-080 | 0~7.0 | 0~1.0 | 8 | 19.6 | Nothing | 200 | 8.6 | -10~70 |

NOTE

- ※1. The allowable rotary speed is based on operating pressure of maximum 7MPa.
1. Please prepare one circuit for drainage between them when the oil slick leak from the hydraulic circuit to adjacent air circuit becomes a problem.
 2. Please avoid continuous operation as it will cause overheating and damage to the internal packing.

External Dimensions: CJRC-020

□ This drawing indicates CJRC-020SA(2 Port Circuit)

When G thread is necessary for a primary side or secondary side port, please contact us separately

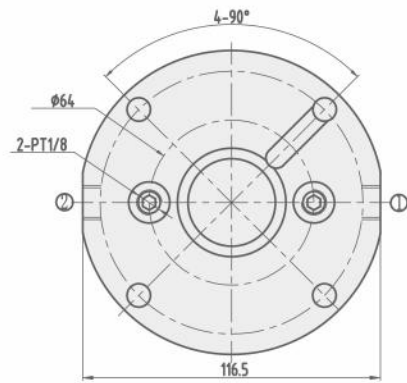

Stop Side

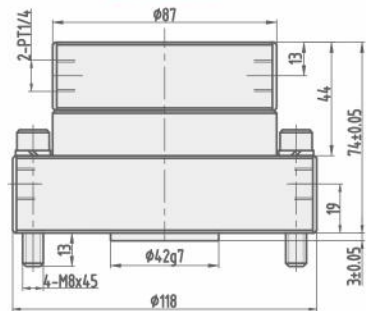

Rotating Side

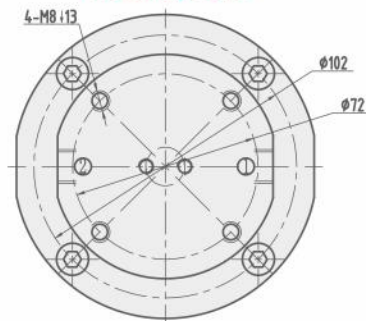

Machining Dimensions of Mounting Area

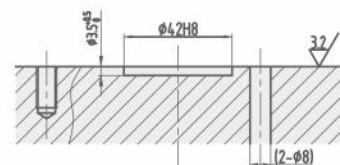
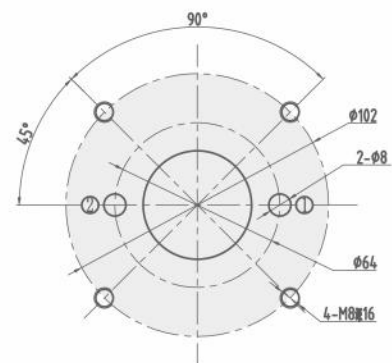

※1. Only in the case of a gasket method, it is necessary. 1. Roughness of mounting surface (O ring sealsurface) should be 6.3S or less.

ORDERING INDICATION CJRC-020BA SD

B S :1 Primary Side Piping Method
A D :2 Secondary Side Piping Method

1. The rotation side must be fixed the flange part with of bolt, and restrain only the rotation direction of the stop side.
2. Please use hose for piping of stop side.
3. Please prepare one circuit for drainage between them when the oil slick leak from the hydraulic circuit to adjacent air circuit becomes a problem.
4. Please avoid continuous operation as it will cause overheating and damage to the internal packing.
5. Each port exhibits a port number.
6. When using Rc1/4 thread for a secondary side port, please attach the attached R1/8 screw plug to the gasket port part. When using gasket option, please attach O-ring and R1/4 plug.

- Incoming Port (2-Rc1/4 Thread)
- Outgoing Port (2-Rc1/4 Thread) with BSPT Plug (R-thread Plug)
- 4xM8x1.25x45 Bolt (included)

- 2-Rc1/8 Thread with BSPT Plug (R-thread Plug)
- Outgoing Port (2-Gasket Port, O-Ring : 1BP12 included)

External Dimensions: CJRC-040

□ This drawing indicates CJRC-040SA(4 Port Circuit)

When G thread is necessary for a primary side or secondary side port, please contact us separately

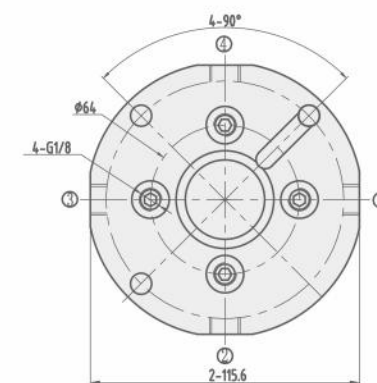

Stop Side

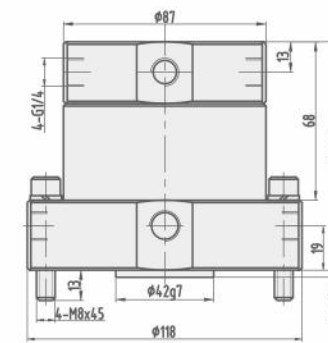

Rotating Side

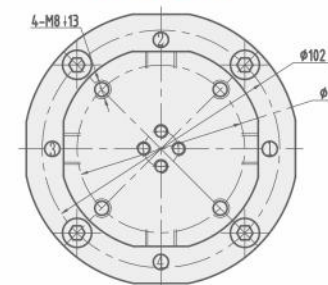

Machining Dimensions of Mounting Area

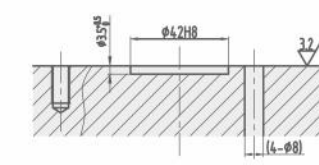
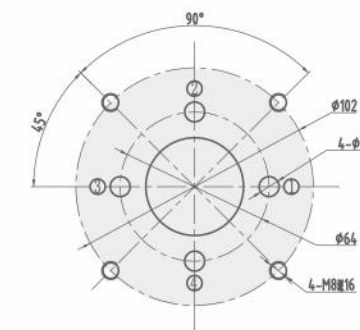

※1. Only in the case of a gasket method, it is necessary. 1. Roughness of mounting surface (O ring sealsurface) should be 6.3S or less.

ORDERING INDICATION CJRC-040BA SD

B S :1 Primary Side Piping Method
A D :2 Secondary Side Piping Method

1. The rotation side must be fixed the flange part with of bolt, and restrain only the rotation direction of the stop side.
2. Please use hose for piping of stop side.
3. Please prepare one circuit for drainage between them when the oil slick leak from the hydraulic circuit to adjacent air circuit becomes a problem.
4. Please avoid continuous operation as it will cause overheating and damage to the internal packing.
5. Each port exhibits a port number.
6. When using Rc1/4 thread for a secondary side port, please attach the attached R1/8 screw plug to the gasket port part. When using gasket option, please attach O-ring and R1/4 plug.

- Incoming Port (2-Rc1/4 Thread)
- Outgoing Port (2-Rc1/4 Thread) with BSPT Plug (R-thread Plug)
- 4xM8x1.25x45 Bolt (included)

- 2-Rc1/8 Thread with BSPT Plug (R-thread Plug)
- Outgoing Port (2-Gasket Port, O-Ring : 1BP12 included)

External Dimensions: CJRC-060

□ This drawing indicates CJRC-060SA(6 Port Circuit)

When G thread is necessary for a primary side or secondary side port, please contact us separately

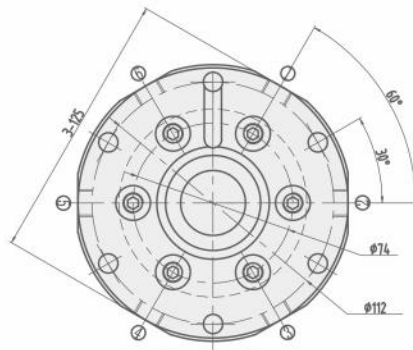

Stop Side

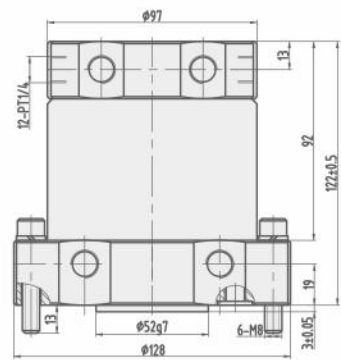

Rotating Side

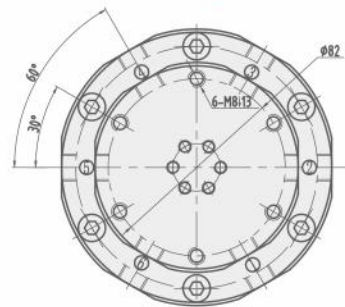

Machining Dimensions of Mounting Area

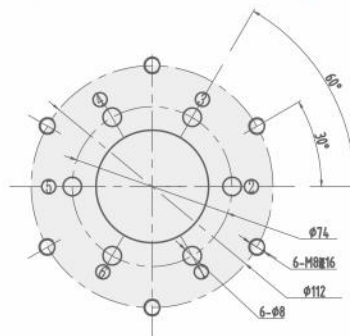

ORDERING INDICATION

CJRC-060BA SD

B S :1 Primary Side Piping Method
A D :2 Secondary Side Piping Method

1. The rotation side must be fixed the flange part with of bolt, and restrain only the rotation direction of the stop side.
2. Please use hose for piping of stop side.
3. Please prepare one circuit for drainage between them when the oil slick leak from the hydraulic circuit to adjacent air circuit becomes a problem.
4. Please avoid continuous operation as it will cause overheating and damage to the internal packing.
5. Each port exhibits a port number.
6. When using Rc1/4 thread for a secondary side port, please attach the attached R1/8 screw plug to the gasket port part. When using gasket option, please attach O-ring and R1/4 plug.

- Incoming Port (2-Rc1/4 Thread)
- Outgoing Port (2-Rc1/4 Thread) with BSPT Plug (R-thread Plug)
- 4xM8x1.25x45 Bolt (included)

- 2-Rc1/8 Thread with BSPT Plug (R-thread Plug)
- Outgoing Port (2-Gasket Port, O-Ring : 1BP12 included)

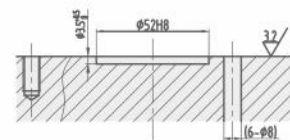

※1. Only in the case of a gasket method, it is necessary. 1. Roughness of mounting surface (O ring sealsurface) should be 6.3S or less.

External Dimensions: CJRC-080

□ This drawing indicates CJRC-080SA(8 Port Circuit)

When G thread is necessary for a primary side or secondary side port, please contact us separately

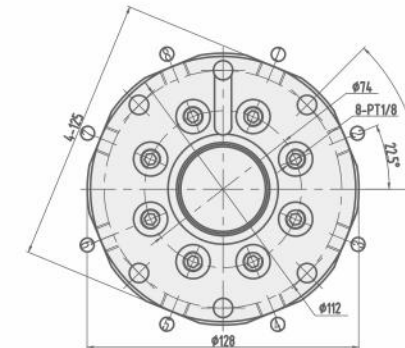

Stop Side

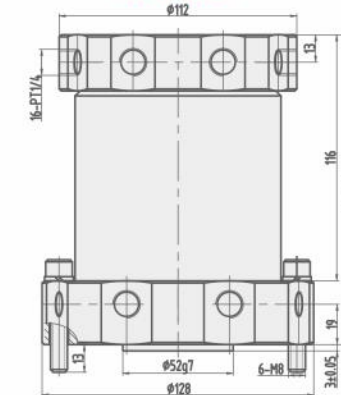

Rotating Side

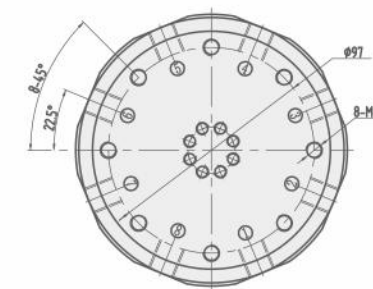

Machining Dimensions of Mounting Area

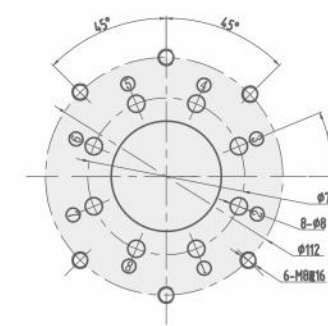

ORDERING INDICATION

CJRC-080BA SD

B S :1 Primary Side Piping Method
A D :2 Secondary Side Piping Method

1. The rotation side must be fixed the flange part with of bolt, and restrain only the rotation direction of the stop side.
2. Please use hose for piping of stop side.
3. Please prepare one circuit for drainage between them when the oil slick leak from the hydraulic circuit to adjacent air circuit becomes a problem.
4. Please avoid continuous operation as it will cause overheating and damage to the internal packing.
5. Each port exhibits a port number.
6. When using Rc1/4 thread for a secondary side port, please attach the attached R1/8 screw plug to the gasket port part. When using gasket option, please attach O-ring and R1/4 plug.

- Incoming Port (2-Rc1/4 Thread)
- Outgoing Port (2-Rc1/4 Thread) with BSPT Plug (R-thread Plug)
- 4xM8x1.25x45 Bolt (included)

- 2-Rc1/8 Thread with BSPT Plug (R-thread Plug)
- Outgoing Port (2-Gasket Port, O-Ring : 1BP12 included)

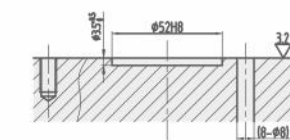

※1. Only in the case of a gasket method, it is necessary. 1. Roughness of mounting surface (O ring sealsurface) should be 6.3S or less.